

BK PRECISION

Instruction Manual

Model 4030 10MHz Pulse Generator

WARRANTY CARD

BK Precision certifies that all products manufactured conform to published specifications and are free from defects in materials and workmanship for a period of One (1) year from the date of delivery when used under normal operating conditions and within the service conditions for which they were furnished.

The obligation of BK Precision arising from a Warranty claim shall be limited to repairing, or at its option, replacing without charge, any product which in BK Precision sole opinion proves to be defective within the scope of the Warranty.

BK Precision must be notified in writing of the defect or nonconformity within the Warranty period and the affected product returned to BK Precision within (30) days after discovery of such defect or nonconformity.

Although Quick Servicing Guidelines are provided in the manual, the unit doesn't contain any user serviceable parts. BK Precision shall have no responsibility hereunder for any defect or damage caused by improper storage, improper installation, unauthorized modification, neglect, inadequate maintenance, accident or for any product which has been repaired or altered by anyone other than BK Precision.

EXCLUSION OF OTHER WARRANTIES

The Warranty described above is Buyer's sole and exclusive remedy and no other warranty, whether written or oral, is expressed or implied. BK Precision specifically disclaims the implied warranties of merchantability and fitness for a particular purpose. No statement, representation, agreement, or understanding, oral or written, made by an agent, distributor, representative, or employee of BK Precision, which is not contained in the foregoing Warranty will be binding upon BK Precision, unless made in writing and executed by an authorized BK Precision employee. Under no circumstances shall BK Precision be liable for any direct, indirect, special, incidental, or consequential damages, expenses, losses, or delays (including loss of profits) based on contract, tort, or any legal theory.

MODEL NO. OF THE INSTRUMENT : **4030**

SR. NO. OF THE INSTRUMENT : _____

Contents

<i>Section</i>	<i>Description</i>
1	SAFETY INSTRUCTIONS
2	SPECIFICATIONS
3	GENERAL DESCRIPTION
3.1	Introduction
3.2	Applications
3.3	Installation Data
3.4	Power Requirements
3.5	Incoming Confidence Check
3.6	Accessories
3.7	Cleaning
3.8	Storage
4	OPERATING INSTRUCTIONS & ADJUSTMENTS
4.1	Front Panel Controls
4.2	Rear Panel Controls
4.3	Precautions

Section 1 Safety Instructions

- 1.1 Prior to applying power to the instrument, ensure that earth is available at the power outlet.
Intentional interruption of the grounding system, by use of two-wire plug adapters or two wire extension cords must be considered an unsafe practice.
- 1.2 Be sure that only correct power fuse with required V/I ratings is installed for replacement purpose.
Incorrect fuse rating can result in fire &/or serious damage or harm to human life & property.
- 1.3  Refer to Manual.

Section 2 Technical Specifications

2.1 FREQUENCY RANGE

Internal	:	0.1Hz to 10MHz in 8 decade ranges & variable.
Stability Internal Mode	:	0.5%.
X'tal Spot Frequencies	:	10MHz, 1MHz, 100KHz, 10KHz, 1KHz, 100Hz, 10Hz, 1Hz.
Stability X'tal Mode	:	200 ppm.
Warm up Time	:	30 minutes.

2.2 TRIGGERING

Internal	:	0.1Hz to 10MHz.
External	:	10Hz to 10MHz.
* Manual	:	1 pulse out for each switch press.
Ext. Trig-Input	:	±1V to ±10V p-p sine & square waveform.
Trig. Output	:	TTL pulse (Zo=50 ohms).

*Manual trigger available for 10 MHz (100 ns) rate only. Not available with any other rate settings.

2.3 FREQUENCY COUNTER

Range	:	0.1Hz to 10MHz.
Display	:	4 digit counter with Internal, External and Auxiliary mode.
Display Accuracy	:	±0.5% ±1 count.

2.3 RATE : 100nsec - 0.1sec (8 decade range & variable adj.).

2.4 WIDTH : 50nsec - 50msec (0 decade range and variable).

2.5 DELAY : 0 - 2µsec variable w.r.t. trigger output.

- 2.6 OUTPUT POLARITY** : Normal / Inverting.
- 2.7 OUTPUT**
- Pulse Out : 0.5V - 5V at 50 ohms.
- Impedance : 50 ohms.
- Rise & Fall Time : 12nsec.
- Output Terminal : BNC connector.
- 2.8 POWER SUPPLY**
- Voltage : 115V & 230V AC $\pm 10\%$, 47Hz - 63Hz switchable.
- Consumption : 10VA.
- 2.9 PHYSICAL**
- Dimensions (WxHxD) : 10.8 x 3.4 x 12.2 (275 x 86 x 310 mm) approx.
- Weight : 6.6 lbs. (3 Kgs.) approx.

Section 3 General Description

3.1 INTRODUCTION

BK Precision's Pulse Generator Model 4030 is specifically designed to include only the basic facilities of a Pulse Generator in order to make it handy and easy to operate unit. It offers pulse repetition rate from 0.1Hz to 10MHz with rise & fall time <12nsec, pulse width from 50nsec to 50msec & pulse amplitude from 0.5V to 5V across 50 ohms. Provision for external triggering and monopulse generation is also done.

The x'tal mode gives accurate eight spot frequencies derived from 10MHz crystal source.

This manual contains information pertaining to the specifications, installation and operation of Pulse Generator Model 4030.

3.2 APPLICATIONS

The name Pulse Generator tends to conjure up images of an instrument that is primarily intended for use with digital circuit. The generator can be used to test the digital circuits to provide noise-free pulse, to define the resonant frequency of the L-C circuit, defining R-C times testing the quality of power supply, to test power amplifiers. Naturally, the most common application of the 4030 pulse generator is in the design, testing and servicing of circuits that normally use pulse signals, especially digital logic circuits. The 4030 can generate the same type of signal as normally used in the circuit for signal substitution or signal tracing methods of troubleshooting. The pulse generator is useful when driving circuitry that cannot accept negative voltages. An oscilloscope is normally used to examine the output of the circuit while the pulse generator supplies the input.

3.3 INSTALLATION DATA

The instrument is shipped ready for bench operation. The front panel must remain unobstructed to allow cable connections and switch/knob operation.

Do not throw the packing material, as it can be useful while returning the instrument to factory for calibration / servicing.

3.4 POWER REQUIREMENTS

Model 4030 has a three conductor self power cord that grounds the instrument chassis when connected to a compatible power receptacle. The instrument operates over a nominal 115V & 230V AC $\pm 10\%$, 47Hz - 63Hz supply.

3.5 INCOMING CONFIDENCE CHECK

Prior to packaging the instrument for shipment, extensive operational and calibration procedures were performed to verify conformity to specifications. To ensure the electronic integrity of the instrument, you must perform the following confidence check.

Adjust the settings by using range select switch and controls.

1. Model Select : X-TAL.
2. Rate (s) : 1MHz
3. Width (s) : 50ns to 500ns.
4. Width Control : Minimum.
5. Output : Maximum.

Check the output pulse waveform on oscilloscope. Check all the controls and 'Polarity' control.

3.6 ACCESSORIES

1. BNC to BNC - 1 No.
2. 50 ohms Termination - 1 No.
2. Operation Manual - 1 No.

3.7 CLEANING

As an electronic instrument, due care should be taken to keep the instrument away from dusty environment. The customer is advised to clean only the external part of the instrument with a soft moist cloth. Special care should be taken while cleaning the front panel. No chemicals or solvents must be used to clean the instrument.

3.8 STORAGE

There are no special instructions for storage. The instrument should be shelved in a reasonably clean environment and protected from dirt and moisture. Do not wrap airtight with plastic.

Section 4

Operating Instructions & Adjustments

4.1 FRONT PANEL CONTROLS

The front panel controls are functionally grouped and clearly designated for ease of operation. Their functions are described below:

1. DISPLAY
This 4 digit 7 segment display indicates rate frequency.
2. RATE (Variable)
The period is short at "MIN" position (counter clockwise) and period is long at "MAX" position as a pulse period (or frequency) variable controller.
3. DELAY (Variable)
To delay the pulse out against trigger output. The variable limit is 0 - 2 μ s.
4. WIDTH
To control the pulse width.
5. OUTPUT LEVEL POT
Pulse output level controller (1V - 10V).

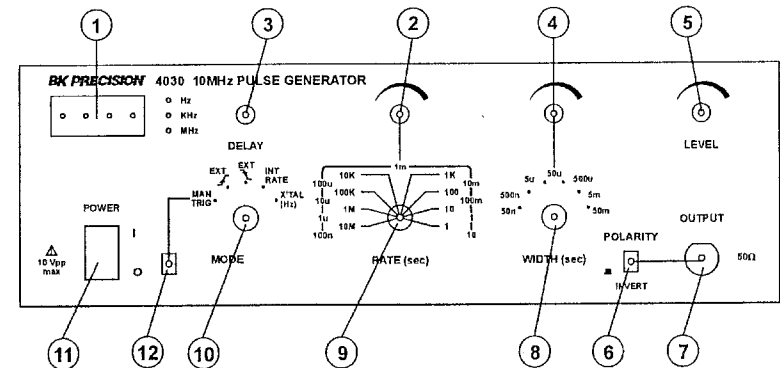

Fig. 1 Front Panel Controls

6. POL
Output polarity select switch of pulse.
7. OUTPUT BNC CONNECTOR
The pulse out BNC-connector with output impedance of 50 ohms.
8. WIDTH (S) RANGE
As a pulse width time select switch it has a 5 range of 50ns - 5ms.
9. RATE (S) RANGE

As a pulse period time select switch it has a 8 range of 100ns - 10s.
 Also by the crystal oscillator (10MHz, 1MHz, 100KHz, 10KHz, 1KHz, 100Hz, 10Hz and 1Hz. (Note: If using manual trigger, 10 MHz must be selected. Manual trigger is not available in any other rate ranges.)

10. MODE

X-TAL

It is a standard frequency oscillator mode select. It is generated the standard frequency by crystal oscillator circuit.

INT RATE

As a internal trigger mode switch to trigger the pulse circuit by internal oscillator frequency and rate is controlled by the "RATE" pot.

EXT TRIGGER

Ext. Trigger rising & falling edge selector.

MAN TRIGGER*

Manual trigger mode selector.

*Manual trigger available only when rate is set to 10 MHz (100 ns) only. Not available with other rate ranges.

11. POWER ON SWITCH

This is a Power ON / OFF switch.

12. PUSH ON SWITCH

One pulse is generated when push the button under mode setting of manual trigger position.

4.2 REAR PANEL CONTROLS

1. TRIGGER IN BNC

The maximum input of trigger input BNC connector is 10Vp-p.

2. FUSE

This is a fuse in series with mains supply.
 (For 230V - 250mA & For 115V - 500mA)

3. BNC SYNC OUT

As a trigger out BNC connector output impedance is 50 ohms with TTL level output.

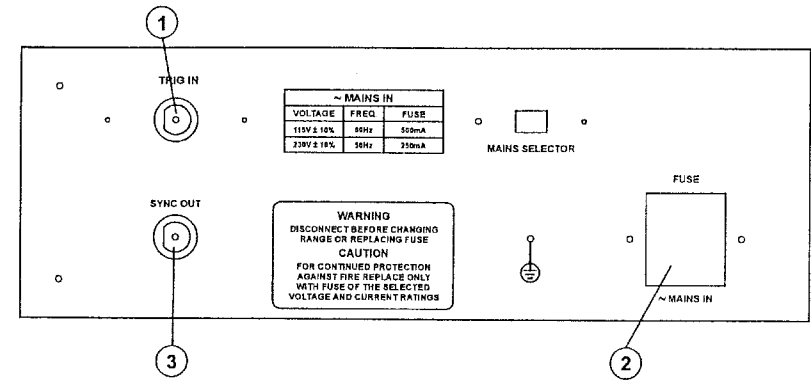

Fig. 2 Rear Panel Controls

4.3 PRECAUTIONS

To obtain the optimum performance of the 4030, the following procedure should be adopted.

1. Select a location free from dust and humidity.
2. Do not operate the instrument where mechanical vibrations are excessive or near a instrument which generates strong electric or magnetic fields.
3. Ensure that proper mains voltage 115V AC or 230V AC is selected. Failure to do so may permanent damage the instrument.

4.4 TROUBLESHOOTING

- Using Manual Trigger

In order to use the manual trigger, you must have the "Rate" switch in the 10M/100nS position. This is the only way to access the manual trigger function. If you set the Rate switch to the 10M position and the "Width" switch to the 50mS and the "Mode" switch to manual trigger, then set the volt/division switch on your O-Scope to 2V or 5V and your time/division respectively at 50mS. When you push the manual trigger you will see a 50mS pulse (one division horizontally). You may have to push it a couple of times because sometimes the trigger pulses off the screen. To verify that the pulse is actually triggering you can hook the unit up to a counter that has a "Total" feature. Every time you push the trigger the counter will count 1 pulse. If you change your volts/division switch to 500mS and leave all the other settings the same as above, you will see the pulses very clearly.

To continue viewing the trigger, make sure that the "Width" switch and the time/division switch on your O-Scope match. There will come a point where the trigger is too fast for your eye to view it using an analog scope. If you leave the time/division at 500mS or 50mS you will be able to view faster pulses but it will be a very dim and quick dot and you will have to look closely to see it; but once again, verify the pulse by the counter. It should go up 1 every time you push the button.