

Table of Contents

For Safe Operations vi
INTRODUCTION vii

SECTION 1 COMPOSITION

Contents of the Package 1-1

SECTION 2 PREPARATION FOR USE

Safety Checks 2-1
 Environmental Conditions of the Place for Installation 2-1
 Safety Checks 2-1
 Preamplifier Selection 2-1
 Coaxial Cable Specifications 2-2
 Connection with the Measuring Instrument 2-2

SECTION 3 COMPONENT NAMES AND FUNCTIONS

Component Names 3.1
 Component Description
 Magnetic field detection unit (glass ceramic board) 3.1
 Tip protective cover 3-2
 SMA connector 3-2

SECTION 4 OPERATING PROCEDURE

Measurement Procedure 4-1
 Stopping the Measurement 4-2
 Connecting the Coaxial Cable 4-3
 Holding the Probe 4-5

SECTION 5 MEASUREMENT

Magnetic Field Measurement on a Pattern ----- 5-1
Determining the Magnetic Field Strength ----- 5-3

SECTION 6 CHARACTERISTICS

Electrical Characteristics ----- 6-1
General Specifications ----- 6-1

SECTION 7 MAINTENANCE

Cleaning the Probe ----- 7-1
Storing the probe ----- 7-1

For Safe Operations

The instructions to be followed in operating the product with maximum safety are described below. Before operating the product, be sure to read them thoroughly.

The following safety precautions are contained in this manual to ensure safe operation of the product.

CAUTION

Used for explaining general handling precautions or indicating a potentially hazardous situation which, if not avoided, may result in damage to the product or other measuring instruments

WARNING

Used for indicating a potentially hazardous situation which, if not avoided, could result in death or serious injury such as electric shock

Safety Instructions

Operations

Magnetic field strength/current measurements cannot be performed by this product alone. The output voltage of the product should be measured with an appropriate measuring instrument such as a spectrum analyzer.

The measuring instrument connected with the product should be operated, following the precautions given in its instruction manual.

Warning and Caution



- This product is a magnetic field probe designed specifically for use in measuring magnetic field strength and electric current. The product cannot be combined with a signal generator to generate noise.
- Never attempt to modify or disassemble the product.
- Exercise care not to drop the product or give a strong impact to it, or it may suffer damage.
- Do not use the product in a manner not designated in this manual, or it may not only fail to provide accurate measurements, but also suffer damage.
- To avoid hazards, do not handle the product with moistened conditions.

INTRODUCTION

Product Overview

The CP-2S is a magnetic field probe designed specifically for use in measuring accurately high-frequency magnetic field strength and electric current at LSI terminals or on printed circuit boards. This probe is connectable with any common measuring instruments such as a spectrum analyzer—simply by connecting this product with an appropriate measuring instrument, it can be immediately used for searching for EMI and other noise sources.

To achieve miniaturization and high spatial resolution (high measurement efficiency), a glass ceramic circuit board superior in high-frequency response characteristics is employed for the magnetic field detection unit.

Major features of this product are as follows:

- *Covers the frequency range of 10 MHz to 3 GHz.
- *The outside dimension of the magnetic field detection unit has been reduced to 2 mm.
- *High spatial resolution of 0.25 mm (6 dB drop point)
- *At least 20 dB electric field shield characteristics
- *A calibration factor data sheet is supplied as an accessory for determination of magnetic field strength.

SECTION 1 COMPOSITION

Contents of the Package

The items shown in Table 1-1 are contained in the package. If any of these items are missing, contact your local dealer. They may differ in shape from their illustrations given in the figure below.

Table 1-1

Item	Qty	Remarks
Main unit	1	Contained in the storage case.
Conversion adapter	2	Contained in the storage case. Used for connection between the main unit and the coaxial cable.
Storage case	1	Used for storing the CP-2S.
Instruction manual	1	The present document
Calibration factor data sheet	1	Factor for converting the output voltage of the probe to a magnetic field strength.

Main unit (CP-2S)



Conversion adapter

junction adapter
(JACK - JACK)L-shaped adapter
(PLUG - JACK)

Storage case

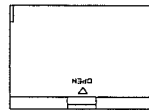

Fig. 1-1

※The storage case is provided with a space for storing one unit of MP-10L LSI Power Wiring Magnetic field Probe (option).

※Additional information may be given on an attached sheet supplied with the product. If so, be sure to refer to the information.

SECTION 2 PREPARATION FOR USE

Safety Checks

Before operating this probe, please keep in mind the information set forth in "For Safety Operations" at the beginning of this manual to ensure safe operation of the probe. Before connecting the probe to the measuring instrument, securely make safety checks, following the directions given in this section.

Environmental Conditions of the Place for Installation

This probe is designed to operate normally within the temperature range of +10°C to +40°C. To obtain optimum performance from the probe, avoid using it in any of the following locations.

- *Place subject to excessive vibration
- *Moist or dusty place
- *Place exposed to direct sunlight

Safety Checks

Before connecting this probe to the measuring instrument, make the following checks. Turning on the measuring instrument without making the checks may cause electric shock, leading to personal injury or damage to the measuring instrument.

- *Check the resin cover and SMA connector for breakage.
- *Check the glass ceramic board at the tip of the probe for breakage.

Preamplifier Selection

It has been verified that the output voltage of the probe varies in proportion to frequency over the range of 10 MHz to 3 GHz and it acts as a loop-type magnetic field probe. Since the probe does not have sufficient sensitivity at low frequencies, it is recommended to use a preamplifier where needed.



The output section of the probe is not provided with a protective circuit. If the probe detects a signal such as would exceed the maximum rated input level for the preamplifier, the input circuit of the preamplifier may be burnt. Similarly, if the output of the amplifier exceeds the maximum rated input level for the measuring instrument, the input circuit of the measuring instrument may be burnt. The preamplifier should therefore be selected after checking the actual detection level of the probe.

Coaxial Cable Specifications

This probe does not come with a coaxial cable. Use a coaxial cable conforming to the following specifications. For details on the use of a coaxial cable or for information on recommended coaxial cables, contact your local dealer.

*Characteristic impedance: 50 Ω

*The cable shall be doubly shielded so as not to be easily affected by ambient noise.

*The connector on the probe side shall be of an SMA type (SUB-MINIATURE TYPE A) which conforms to MIL-C-39012.

*Frequency range: 3 GHz or higher (The full performance of the probe shall be delivered.)

*The coaxial cable shall be flexible so that no excessive stress may be applied to the probe.



If an inappropriate coaxial cable is connected with the probe, the probe not only fails to provide accurate measurements but also suffer damage.

Connection with the Measuring Instrument

The measuring instrument connected to the probe should be of a 50 Ω type. The performance reliability of the probe is not assured when use is made of another type of measuring instrument.



The output section of the probe is not provided with a protective circuit. If the probe detects a signal such as would exceed the maximum rated input level for the measuring instrument, the input circuit of the measuring instrument may be burnt. When there is a possibility that the detection level of the probe may exceed the maximum rated input level for the measuring instrument, insert an attenuator between the measuring instrument and the probe.

SECTION 3 COMPONENT NAMES AND FUNCTIONS

Component Names

The name of the main components of the probe are shown in Fig. 3-1.

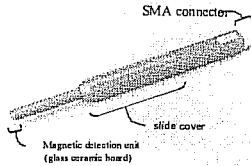

Fig. 3-1

Component Description

Magnetic field detection unit (glass ceramic board)

The width of the magnetic field detection unit is 2 mm.

The magnetic field output of the detector is transmitted to the measuring instrument via the SMA connector.

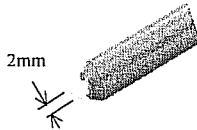
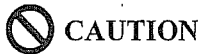

Fig. 3-2



Care should be taken in handling the probe although the glass ceramic board has sufficiently high strength under normal operating conditions.

- *Do not drop the probe or give strong impact to it, or the glass ceramic board may break or chip.
- *Do not modify the glass ceramic board, or the probe may not only fail to provide accurate measurements but also suffer damage.

Tip protective cover

A slide cover is provided to protect the glass ceramic board which constitutes the magnetic field detection unit of the probe.

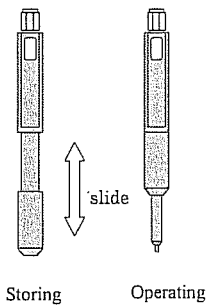

Fig. 3-3

SMA connector

The connector provided on this probe is of an SMA type (PLUG). The coaxial cable or junction adapter to be connected to the probe should be of an SMA type which conforms to MIL-C-39012.

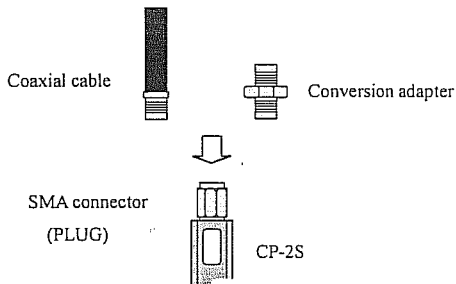

Fig. 3-4

SECTION 4 OPERATING PROCEDURE

Measurement Procedure

Remove the tip protective cover, following the steps shown below.

To prevent damage to the magnetic field detection unit (glass ceramic board), this operation should be performed after connecting the coaxial cable.

①

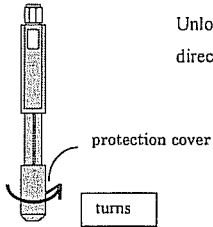

Unlock the tip protective cover by turning it in the direction of the arrow.

②

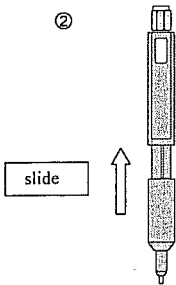

Slide the tip protective cover toward the SMA connector, and the magnetic field detection unit (glass ceramic board) will be exposed to view.

Slide the tip protective cover as far as it goes

③

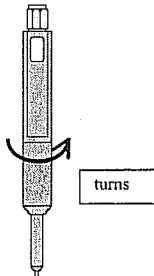

To prevent the tip protective cover from falling down, lock it by turning it in the direction of the arrow.

Stopping the Measurement

Install the tip protective cover, following the steps shown below.

To prevent damage to the magnetic field detection unit (glass ceramic board), this operation should be performed before removing the coaxial cable.

After completing the operation, be sure to store it in the dedicated storage case.

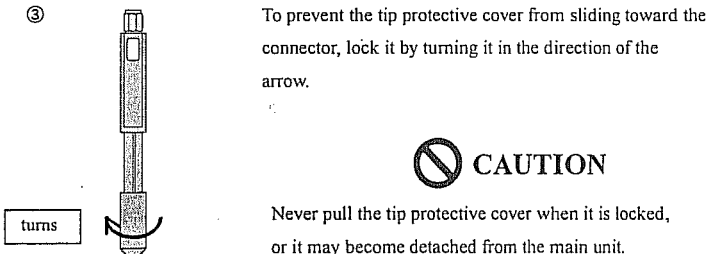
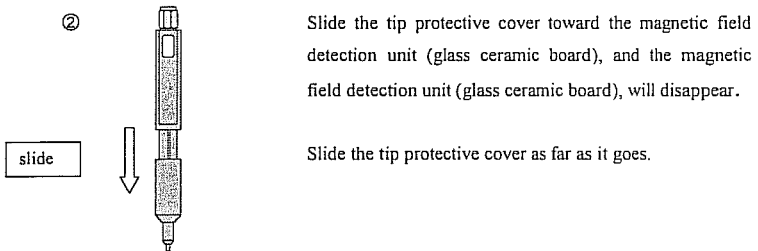
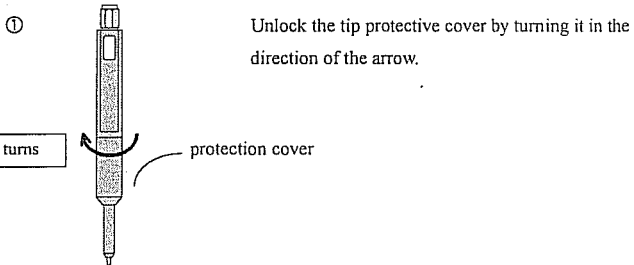

CAUTION

Never pull the tip protective cover when it is locked, or it may become detached from the main unit.

Connecting the Coaxial Cable

Connect the coaxial cable to the SMA connector (PLUG) on the probe so that it will not wobble or come loose. When the coaxial cable is provided with an SMA connector (PLUG), use the junction adapter supplied with the probe, as shown in Fig. 4-2.

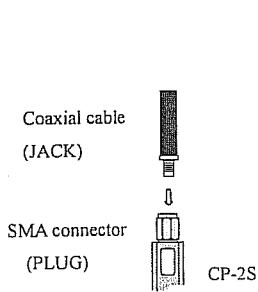

Fig. 4-1

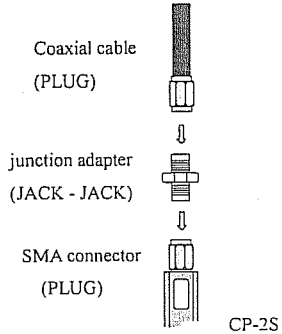

Fig. 4-2

The portion of the coaxial cable near the probe should be kept straight to prevent the SMA connector from being subject to stress.

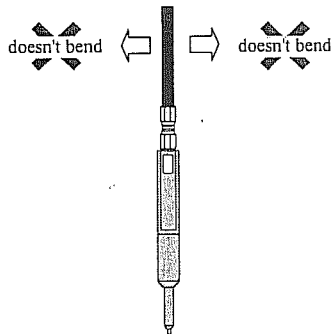

Fig. 4-3

When the coaxial cable cannot be secured in the vertical direction or when it is to be connected in the horizontal direction, use the L-shaped adapter supplied with the probe, as shown in Fig. 4-4.

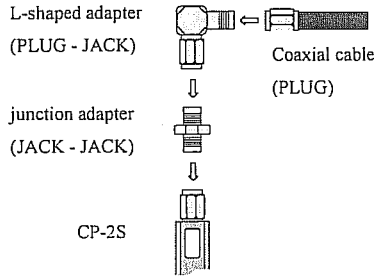

Fig. 4-4

⊘ CAUTION

If a more than 1 kg load is imposed on the SMA connector (or the junction/conversion adapter), the SMA connector and the resin cover may sustain damage.

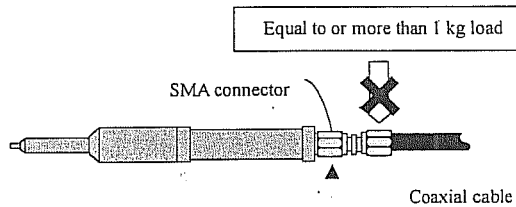

Fig. 4-5

Holding the Probe

The probe should be held at the position shown in Fig. 4-6.

Holding the tip protective cover may disable its lock function, thereby causing it to be unlocked.

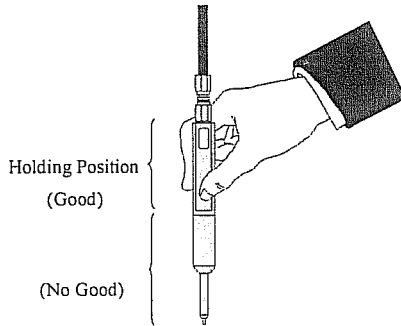

Fig. 4-6

CAUTION

- *Do not drop the probe from a height of 1 cm or more.
- *Do not impose a more than 1 kg vertical load on the probe.
- *Do not impose a diagonal load on the magnetic field detection unit (glass ceramic board).

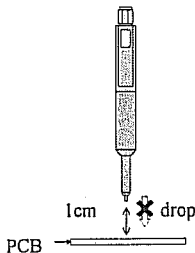

Fig. 4-7

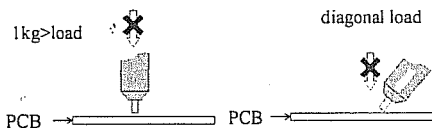

Fig. 4-8

Fig. 4-9

SECTION 5 MEASUREMENT

High-frequency magnetic field strength measurement should be performed on the printed circuit board pattern with reference to the information give in the previous sections.

When connected to an appropriate measuring instrument such as a spectrum analyzer, this probe can detect a magnetic field over the range of 10 MHz to 3 GHz by its detection unit at its tip. Since this probe is basically equivalent in structure with loop probes, it can not only be used for magnetic field strength measurements on patterns but also be used as an ordinary magnetic field probe.

Magnetic Field Measurement on a Pattern

Operating procedure

(1) Connecting the probe to the measuring instrument

Using an appropriate coaxial cable, connect the probe to the INPUT terminal of the measurement instrument (e.g., spectrum analyzer), as shown in Fig. 5-1.

The limit of measurement is determined by the input sensitivity of the measuring instrument. When the detection level of the probe is not enough to provide sufficient sensitivity, insert a preamplifier between the measuring instrument and the probe.

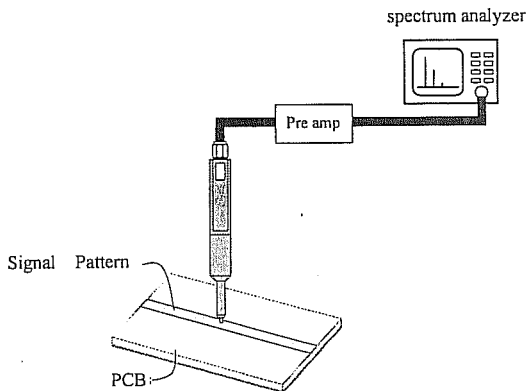

Fig. 5-1

(2) Bring the probe into contact with the printed circuit board so that the glass ceramic board (2 mm in width), the glass ceramic unit of the probe, comes in parallel with the pattern. To check the positional relationship between the magnetic field detection unit and the pattern (horizontal direction), use the marker at the tip.

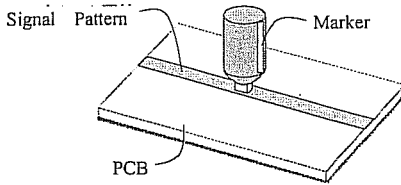

Fig. 5-2

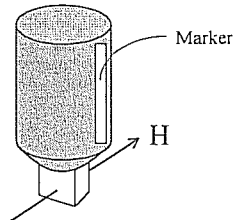

Fig. 5-3 (enlarged view)

As shown in Fig. 5-3 (enlarged view), this probe detects only the magnetic field that is perpendicular to the detection unit. The magnetic field on pattern (microstrip line) can therefore be detected by setting the probe as shown in Fig. 5-2.

⊘ CAUTION

- *Do not strongly push or strike the glass ceramic board (magnetic field detection unit) against the measured object.
- *Do not move the probe or the object under measurement with the glass ceramic board in contact with the object under measurement. When the tip of the glass ceramic board or the object under measurement is to be moved, separate the probe from the object under measurement.
- *Before bringing the glass ceramic board into contact with the object under measurement, check to be sure that the object under measurement is free of dirt, dust, or any other foreign matter.

(3) Measure the magnetic field strength, which has been detected by the magnetic field detection unit of the probe, with the measuring instrument.

The data captured by the measuring instrument is the output voltage (spectrum) of the probe.

Determining the Magnetic Field Strength

This probe performs magnetic field calibration by the microstrip line method.

The magnetic field strength (dB μ A/m) can be determined by adding the value shown in Fig. 5-4 to the output voltage (dB μ V) of the probe.

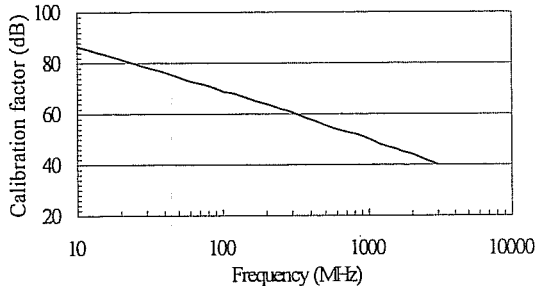

Fig. 5-4

*Magnetic field strength [dB μ A/m] calculation formula

$$H_f = V_f + A_f \quad \text{--- Formula 5-1}$$

H_f = magnetic field strength (dB μ A/m) at frequency f

V_f = the output voltage (dB μ V) of the probe at frequency f

A_f = calibration factor (dB) at frequency f --- (Factor for converting the measured voltage (dB μ V) to a magnetic field strength. For calibration factor (amplitude) data, refer to the attached calibration factor data sheet.)

The calibration factor can also be determined from formula 5-2 below. An about ± 1 dB of error may be involved, depending on product variations.

$$\text{Calibration factor (dB)} = -8.1 \ln(\text{frequency [MHz]}) + 106.2 \quad \text{--- Formula 5-2}$$

*When determining the magnetic field strength by calculation, it is common practice to select "dB μ V" as the unit of level measurement.

SECTION 6 CHARACTERISTICS

The electrical performance characteristics of the probe can be obtained when it is used within the ambient temperature range of +10°C to +40°C. The measuring instrument for measuring the output level of the probe should desirably be calibrated to secure the preheat time and accuracy described in its instruction manual.

Electrical Characteristics

Table. 6-1

Item	Specifications
Frequency range	10MHz to 3GHz
Electric shield	< -20dB
Spatial resolution	6 dB drop point About 0.25 mm

General Specifications

Table. 6-2

Item	Specifications
Connector	SMA (PLUG)
Dimensions	Outside dimensions (when in use) : 135 mm (length) × 12 mm (Dia.) Detection unit : 2 mm (width) × 1 mm (thickness) (Glass ceramics)
Weight	About 17g
Impedance of the Measurement receptacle	50ohm
Operating environment	Operating +10°C to +40°C. (Non-condensing)
	Storage +0°C to +45°C. (Non-condensing)

SECTION 7 MAINTENANCE

Cleaning the Probe

Dry the probe with a dry soft cloth. If the probe is heavily soiled with dust, clean it with a water-moistened cloth and then dry with a soft cloth.

CAUTION

- *Since the probe is sensitive to volatile solvents, do not use thinner, alcohol, or benzene for cleaning, or the probe may be deformed or discolored.
- *Since the probe is sensitive to heat, do not place it near heat sources (such as a soldering iron).
- *When handling the probe, be careful not to drop it or give strong impact to it, or the glass ceramic board may sustain damage.
- *Do not cut away any soiled part of the glass ceramic board with a cutter. If the glass ceramic board sustain damage, the probe may fail to operate properly.

Storing the probe

The precautions to be followed in storing the probe are described below.

- *Remove any dust, fingerprints, or stains from the probe before storage.
- *Install the tip protective cover.
- *Put the probe in the storage case. The conversion adapters should also be put in the storage case, together with the probe, so that they may not be lost.
- *Avoid storing the probe in any of the following locations.

- (1) Place subject to direct sunlight or excessive dust
- (2) Highly damp place where condensation would occur on the probes
- (3) Place where the probe might be oxidized or corroded by an active gas
- (4) Place where the temperature and humidity fluctuate violently

磁界校正データシート (Calibration Factor Data Sheet)

型名 (Model Name)

CP-2S

製品シリアル No. (Serial Number)

2S614A

校正年月日 (Calibration Date)

2009-02-05

出荷年月日 (Shipment Date)

2009.2.10

Frequency (MHz)	Calibration Factor (dB)
10	86.6
100	68.7
1000	50.0
2000	44.2
3000	40.1

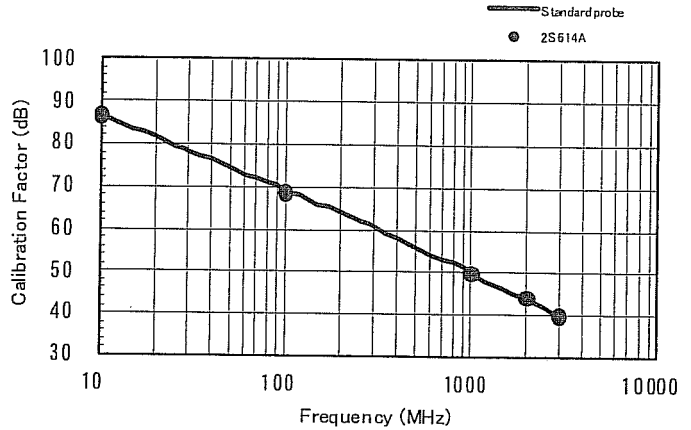

Measurement set-up for probe calibration

Equipment	Part Number	Maker
Spectrum analyzer	MS2663C	Anritsu
Signal generator	8648C	HEWLETT PACKARD

- ① Coaxial cable (2m)
- ② Coaxial cable (2m)
- ③ 50Ω termination
- ④ Microstrip line

